

4.39 DURA • DRIVE PLUS

The Dura Drive Plus one piece motorized pulley is compact yet powerful. All gearing is made of high quality alloy steel ensuring years without breakdown. The Dura Drive Plus is also low maintenance with an in-place oil change after 40,000 hours. This ensures minimal downtime, which in turn ensures lower cost and higher productivity.



Shaft Seal

The end housings are fitted with custom designed one piece cartridge seals. This provides excellent protection against ingress of dust, grit, water and high-pressure cleanings. The cartridge seals are specially designed to prevent wear to the shafts.

Electric Motor

All Sparks Belting motorized pulleys contain motors tested to UL 1004 – 1:2012 standards with Class F insulation standard (Class H insulation available upon request). The motor is an asynchronous squirrel cage induction type. Class F motors are suitable for most applications with ambient temperatures of +100°F to -10°F. For temperatures above or below, contact Sparks Belting for a recommendation.

Electric motors with windings for special voltages and frequencies are available upon request.

Sparks Belting motorized pulleys are inverter duty motors and can, therefore, have a step-less speed control in combination with static frequency converters in the range from 30 to 70 HZ.

Electrical Connections

Pulleys fitted with cables are normally supplied for one voltage only. Dual voltage cable is available upon request.

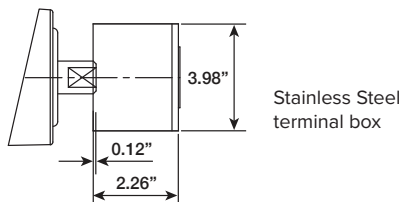
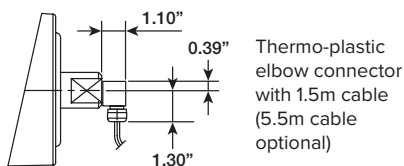
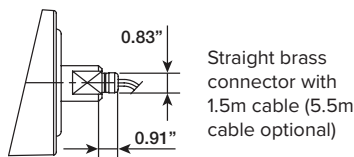

Constructions & Materials

Component	Standard	Options	Not available
Shaft	Mild Steel	Stainless Steel	
Shell	Mild Steel	Stainless Steel	
	Crowned	Rubber Lagged	
		Flat Face	
		V-Grooves	
End Caps		Sprockets	
		Hard Chrome	
	Aluminum	Stainless Steel	Mild Steel
	Pressed/glued	Bolt-on	
Sealing Systems	Cartridge Seal		
Electrical Motor	3 Phase Asynchronous	Dual Voltage	Single Phase
		Thermal Overload Protection	
Electrical Connection	Straight Brass Connector with 1.5m cable (5.5m cable optional)	Thermo-plastic Elbow Connector with 1.5m cable (5.5m cable optional)	
		Steel Conduit Elbow Connector with 1.5m cable (5.5m cable optional)	
		Stainless Steel Conduit Elbow Connector with 1.5m cable (5.5m cable optional)	
		Stainless Steel Terminal Box	
Motor Insulation	Class F	Class H	



Motorized Pulley Dimensions

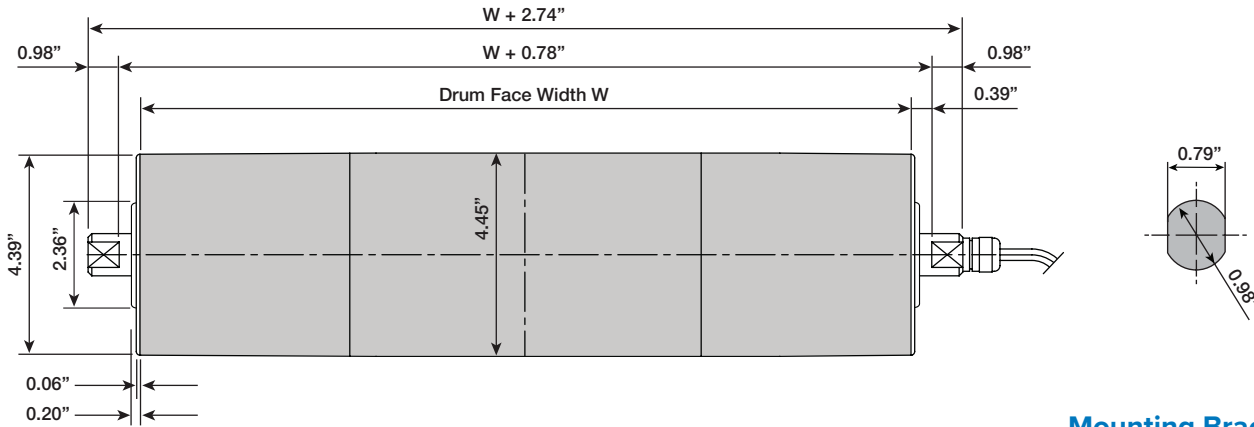

Mounting Bracket

Material: Cast iron or stainless steel bracket

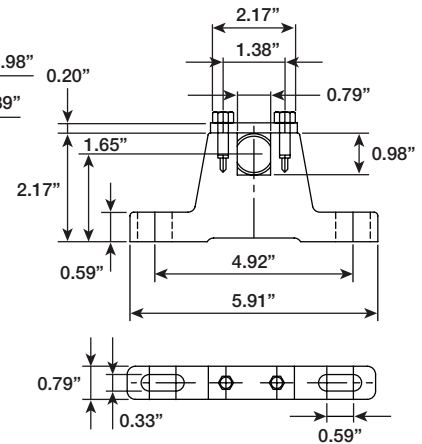

Idler Pulley Dimensions

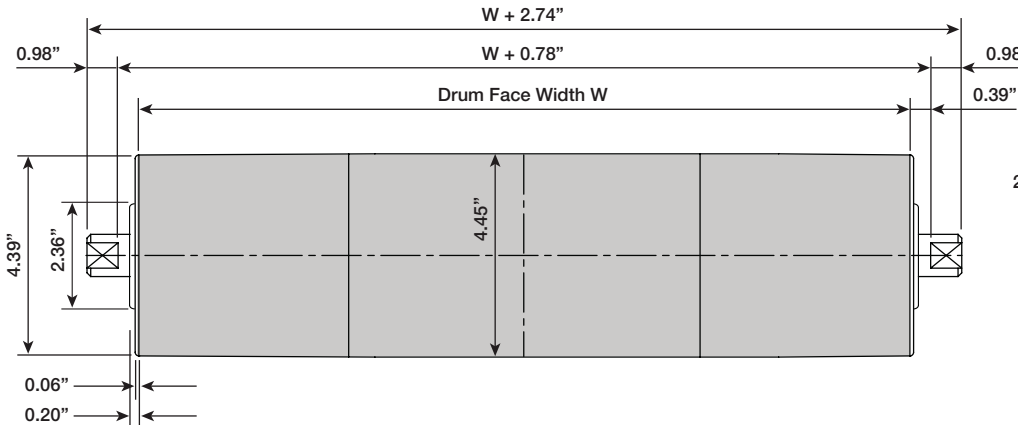

Performance Specifications

HP	Minimum Face Width	FPM (nominal)	Belt Pull (lbs)	Drum Torque (ft/lbs)
0.2	9.84"	47	140	26
		65	97	18
		94	70	13
0.25	11.81"	29	289	53
		41	186	34
0.4	11.81"	47	280	57
		65	198	36
		71	186	34
		94	140	26
		104	124	23
0.5	11.81"	104	151	28
		118	140	26
		142	116	21
		189	87	16
		280	60	11
		325	49	9

Standard Face Widths

9.84" (30 lbs)	11.81" (31 lbs)	13.78" (33 lbs)	15.75" (36 lbs)	17.72" (37 lbs)
19.69" (39 lbs)	21.65" (41 lbs)	23.62" (43 lbs)	25.59" (46 lbs)	27.56" (49 lbs)
29.53" (51 lbs)	31.50" (53 lbs)	33.46" (56 lbs)	35.43" (58 lbs)	37.40" (60 lbs)

- Maximum face width is 59.50"
- Other face widths are available
- Add 1.97" to min. face width for bolt-on end caps
- Maximum lagging thickness is 1/8" (6% increase in finished speed)
- V-groove option must be two times the min. face width
- All motors can be single or dual voltage 230v or 460v 3 phase