

DURA•TECH

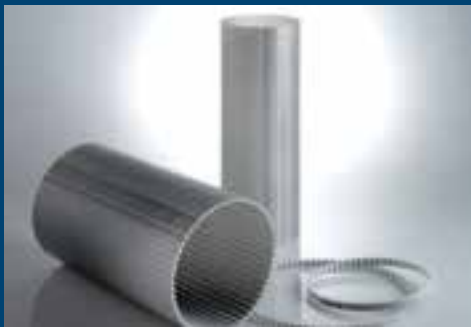

URETHANE TIMING BELT CATALOG

DURA•TECH

Dura-Tech urethane timing belts from Sparks are designed for linear motion, conveying and power transmission applications.

The combination of a wear resistant polyurethane body reinforced with steel or Kevlar® tension members makes Dura-Tech belts ideal for the most severe requirements in all industrial applications.

Dura-Tech is one of several product lines that together enable Sparks to be your complete provider of conveyor belting and custom fabrication solutions.

Material Features

Dura-Tech belts are made from thermoplastic polyurethane.

- Excellent abrasion resistance and impervious to oils, greases, acids and chemicals
- Broad temperature operating range (14 – 176 degrees F)
- Low noise, non-marking and clean operating
- Withstands wet and outdoor environments, and requires no maintenance
- Standard color is white with special colors available, including transparent and black
- Special compounds are available to meet FDA requirements, provide anti-static properties, or high and low temperature requirements

Tension Cords

Steel tension cords are standard on all Dura-Tech belts, requiring low pre-tension and preventing elongation under normal operation for the life of the belt. Reinforcement options include:

- **High Flexibility Steel:** greater resistance to flex fatigue
- **High Performance Steel:** greater strength suitable for higher loads
- **Extra High Performance Steel:** designed for lifting applications
- **Stainless Steel:** recommended for wet applications
- **Kevlar®:** reduces belt weight, increases flexibility, non-magnetic and non-corrosive

Pulleys

Dura-Tech pulleys are available for all Dura-Tech belts.

- **Aluminum pulleys:** lightweight and standard on all **DTT** and **DTA** series belts
- **Steel pulleys** (with pilot bores, or bored and keyed to your specifications) and **cast iron pulleys** (bored to suit taper bushings) meet the rigors of tough power transmission applications and are standard on all **DTI**, **DTH** and **DTS** series belts
- Broad range of teeth available, starting at 10 teeth in the smaller pitches
- Made to match any belt width

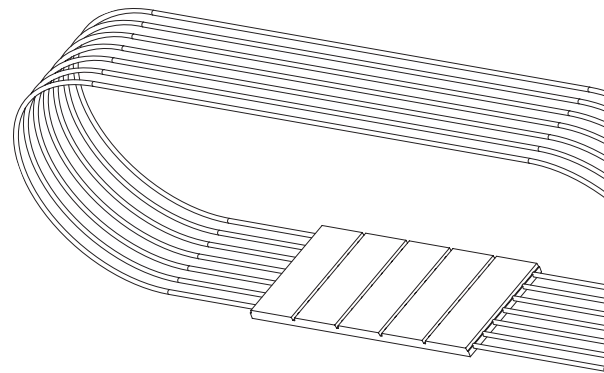

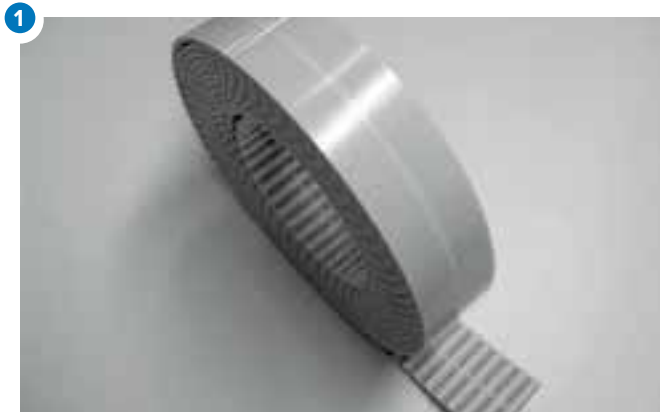

Product Range

1 Dura-Tech Open End Belts

- Produced in standard 100 meter roll lengths, any desired length available
- Offers excellent precision, dimensional stability and high abrasion resistance
- Ideal for all linear motion applications

Dura-Tech Mechanical Spliced Belts

- ### 2
- Uses a square finger joint with connecting pins
 - Allows for simple field splicing where an endless spine is impractical
 - Suitable for most conveying applications

Dura-Tech V-Spliced Belts

- ### 3
- Produced from open end belts
 - Any length available at full tooth increments, starting at 800mm (can be shorter in some instances)
 - Ideal for all conveying applications where synchronization is required

Dura-Tech Truly Endless Belts

- ### 4
- Manufactured with endless tension cords with no splice or welding
 - Ideal for power transmission and high load conveying applications
 - Lengths from 900mm to 22,000mm are available in DTT, DTA, DTI and DTH series belts
 - Short truly endless belts can be produced from molded sleeves and are available in DTT and DTA series belts
 - Contact us for specific sizes available

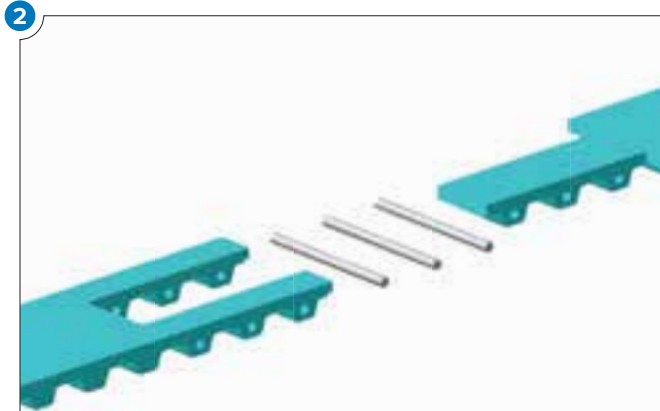

Sparks keeps your product moving.

Founded in 1946, Sparks Belting Company sets the standard for providing application assistance, conveying solutions and technical service to its customers. Sparks offers the widest range of industrial belting available. We successfully design and custom fabricate for our customers' material handling challenges that other companies won't attempt.

Let us help you find or improve a solution for your applications. More information is available at www.sparksbelting.com or call toll free (800) 451-4537.

DIMENSIONS

STANDARD WIDTHS

All dimensions in millimeters unless noted otherwise

DTT Series

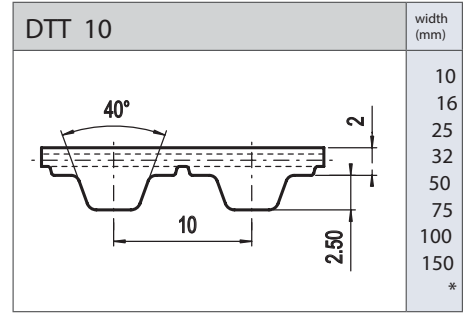
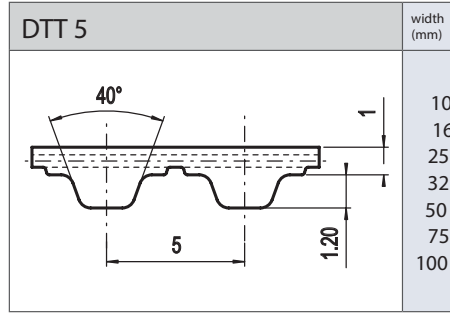
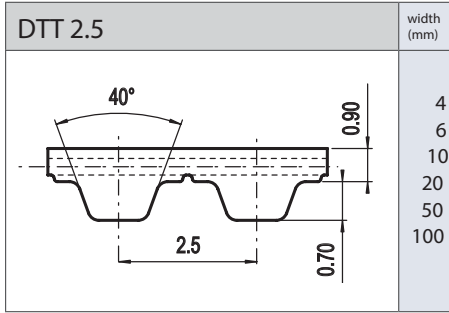

DTK-T Series

*Max. 500mm, in 50mm increments

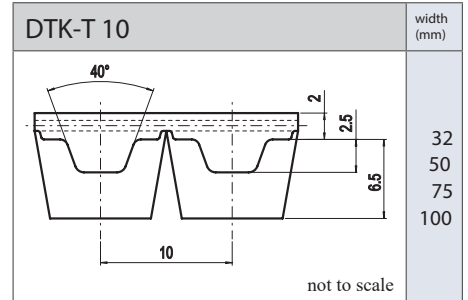
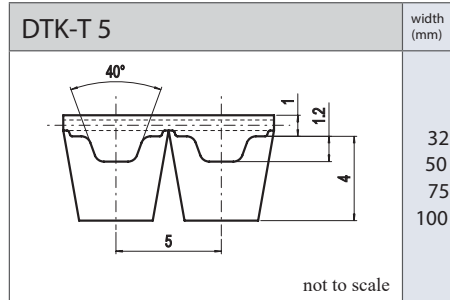
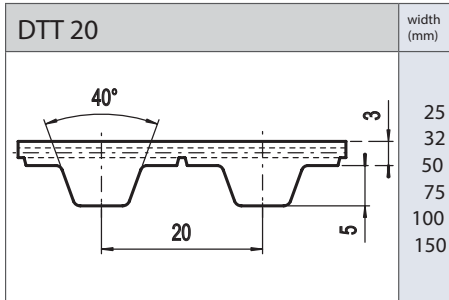

DTA Series

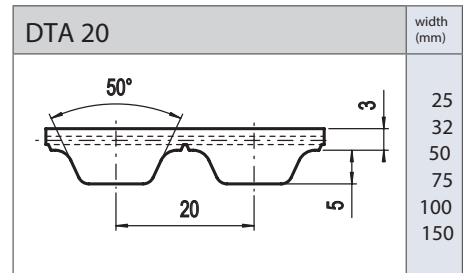
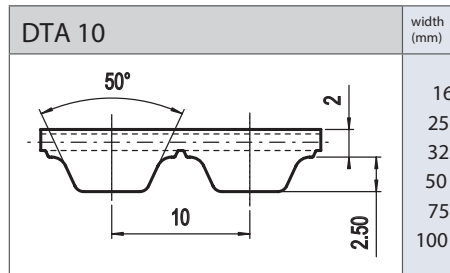
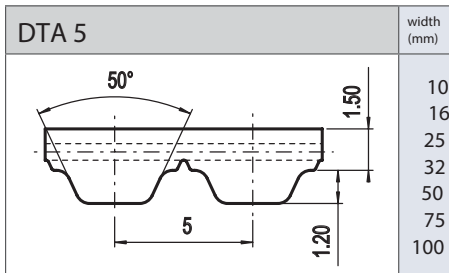

DTK-A Series

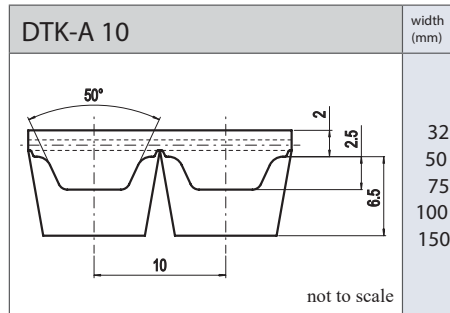
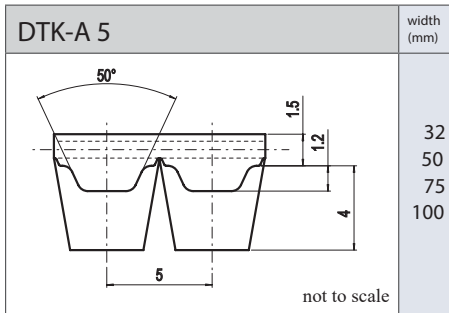

DTI Series (imperial series)

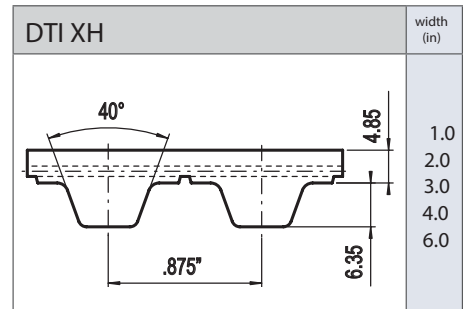
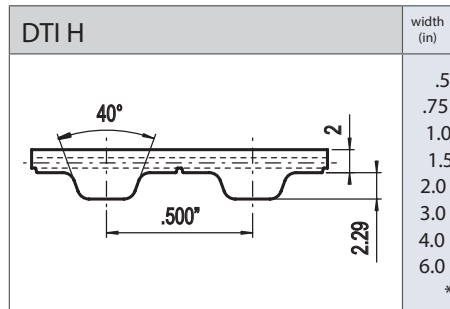
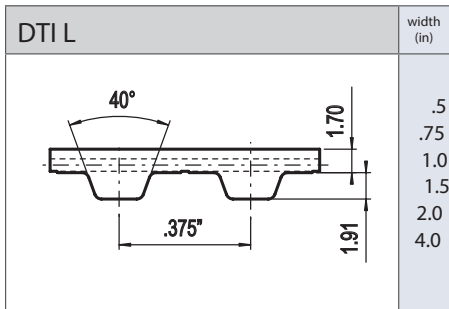

*Max. 20", in 2" increments

DIMENSIONS

STANDARD WIDTHS

All dimensions in millimeters unless noted otherwise

DTH Series

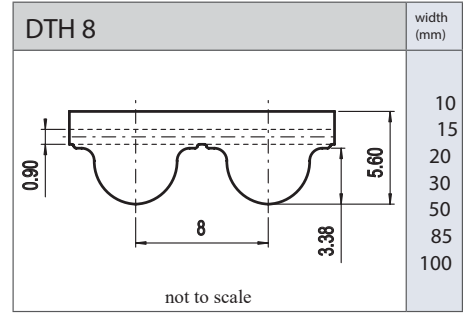
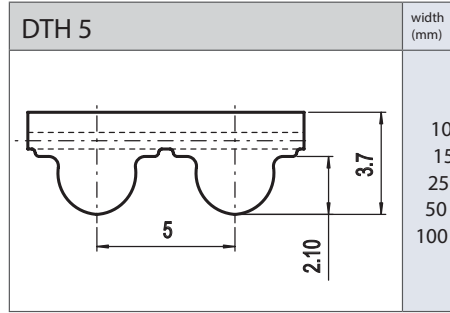
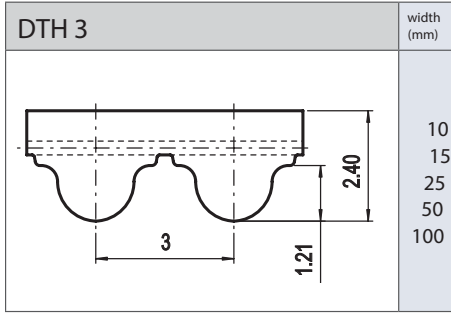

DTS Series

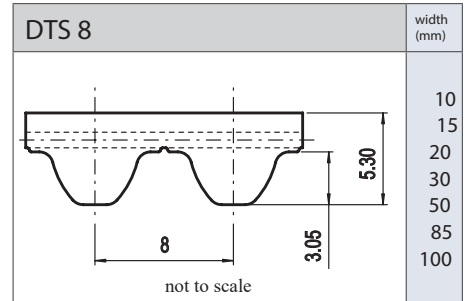
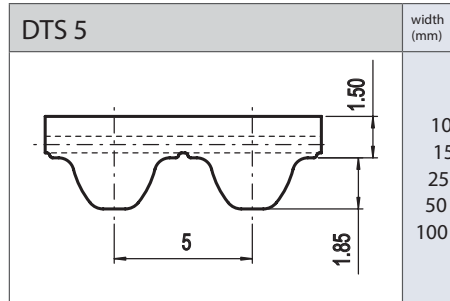
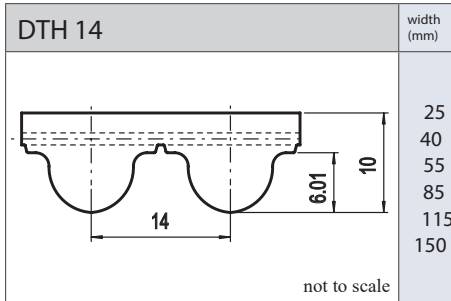

DTR Series

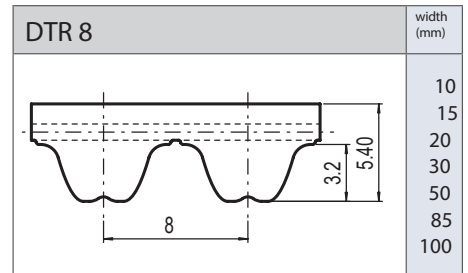
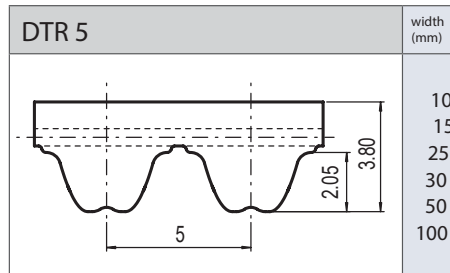
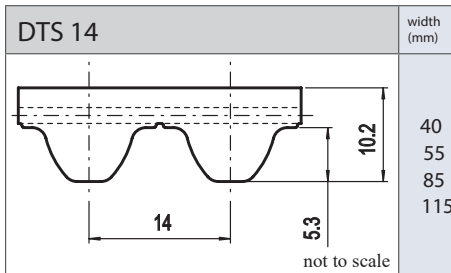

DTF Series

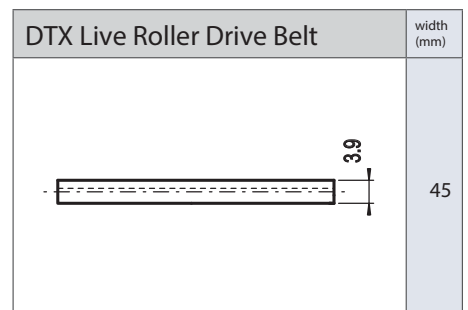
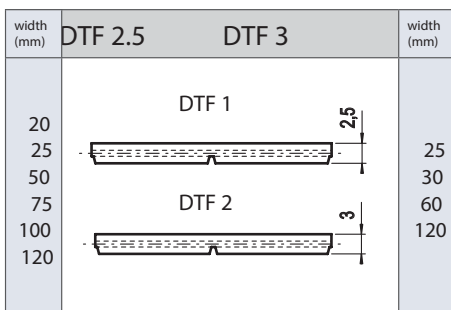
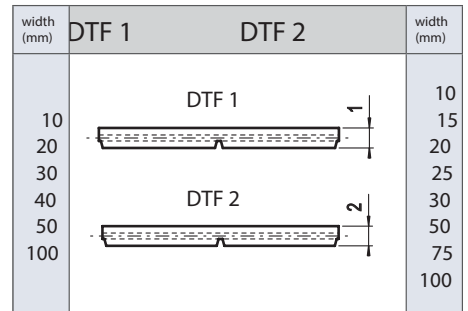
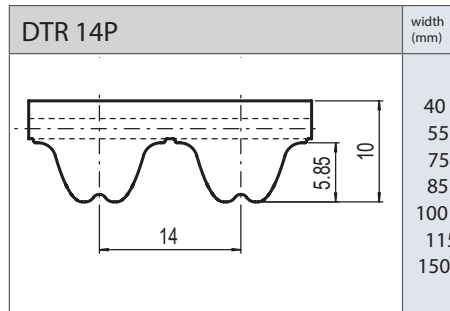
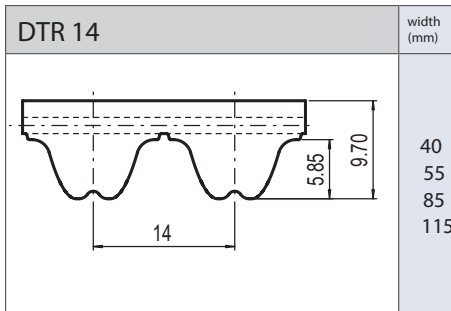

More Belt Features

Double Sided Teeth

Available with double-sided teeth in most styles and pitches for applications that require power transmission on both sides.

Nylon Fabric

- **Tooth side (PAZ)** application reduces the coefficient of friction in slider bed applications, improves tooth engagement and reduces noise on high-speed drives
- **Smooth side (PAR)** application reduces the coefficient of friction on accumulation applications

Cleats

- Welded or mechanically fastened (embedded steel tooth with threaded securing holes extending through the belt)
- Mounting tooth can be full width or embedded in the existing tooth for quieter operation

Perforation

Belts can be perforated for vacuum applications and ground on the tooth or smooth side to accommodate special applications.

Backings

- PVC supergrip Rough Top, blue or green
- PVC, 40 durometer Shore A, 2mm thick, blue or white (FDA)
- Linatex, 1/16" to 3/8" thick
- Synthetic and natural rubbers
- Polyurethane, 70 and 85 durometer Shore A, 2mm to 10mm thick, clear
- Polyurethane 55 durometer Shore A, 2mm to 10mm, yellow
- Polyurethane fishbone pattern, clear
- Polyurethane foam

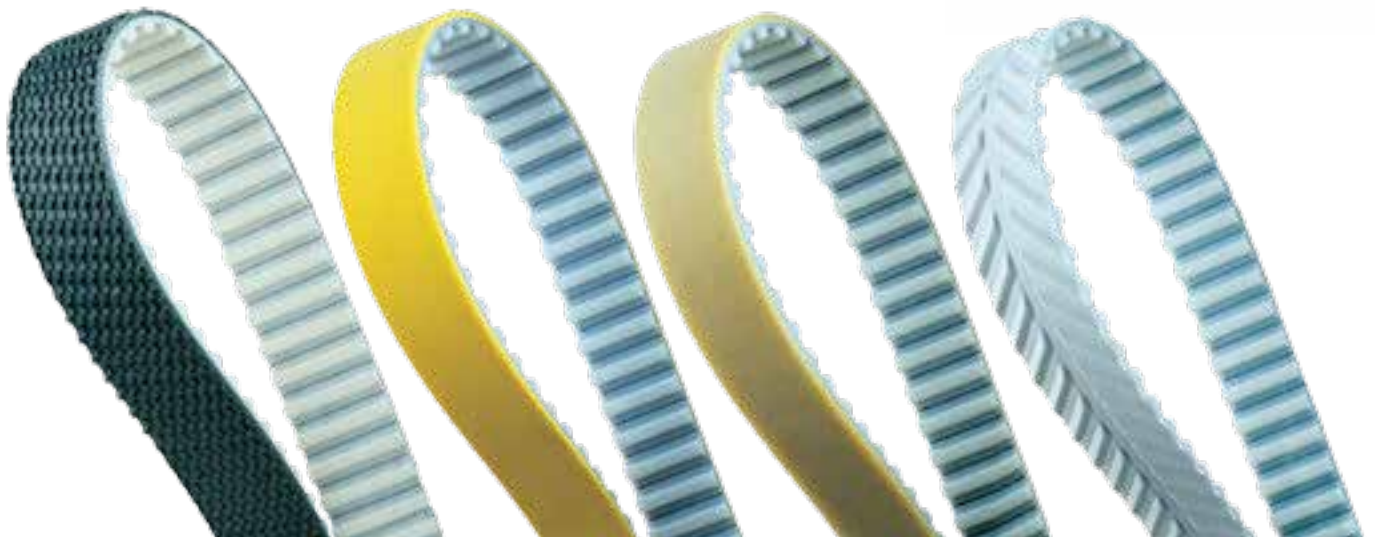

Conveyor Belting and Custom Fabrication

- 200+ standard materials in stock, with custom belting products available
- Full line of custom fabrication services:
 - Endless construction
 - Laced ends
 - Cleats/flights (rib, urethane, T-cleats, super, box, angled)
 - V-Guides (continuous, notched, custom-cast segmented)
 - Corrugated sidewalls
 - Hole punching
 - Capped edges
- Innovative solutions to meet food safety, hygiene, high release, chemical resistance and other challenging operating requirements
- Expertise supporting food grade and industrial OEM applications

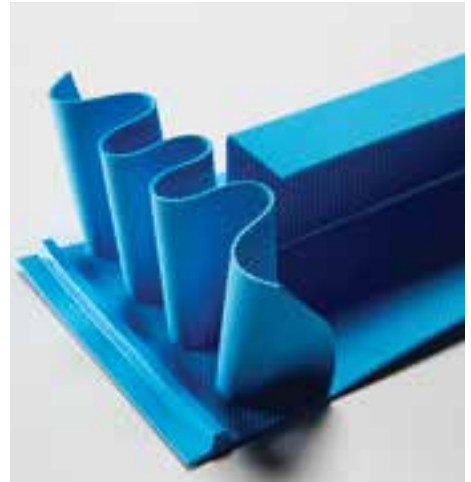

Dura-Lock Plastic Modular Belting

- All standard materials are FDA approved for direct food contact (polyethylene, polypropylene and polyacetal)
- Special materials/additives available for challenging tasks and requirements:
 - Constant high temperature
 - High pulling force
 - Electrical conductivity
 - Non-stick
 - Detectable polyethylene
 - FDA approved, V-O rated flame retardant



Dura-Drive PLUS Motorized Pulleys

- Cost effective alternative to conventional drive pulleys
- One-piece: all moving parts are enclosed in a stainless or regular steel shell
- Energy efficient, highly sanitary, quiet operation
- Low maintenance: no chains or v-belts to tighten or replace; no sprockets to align, clean or lubricate; no bearings to grease; and no chain guards to replace
- Guaranteed to power your belt conveyor for years



All Plastic Flat, Rounds, Vees & Positive Drive Belts

- Innovative plastic positive drive product
- Offers superior hygiene and tracking
- Covers a variety of hardness, colors, unique profiles and reinforcements to meet specific design needs



Quality. Experience. Value.
Sustaining our tradition of
conveying excellence.

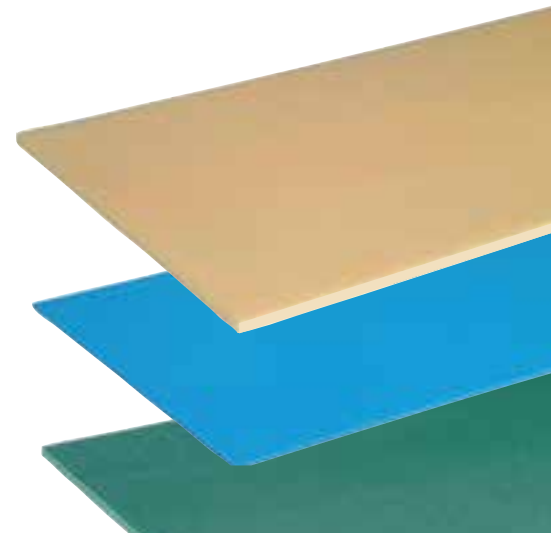

Installation Services

Sparks has a true nationwide footprint that allows us to call on and service any customer in the continuous 48 states. With 75 years in business, we make commitments to our clients like few others in the industry. Bottom line is—

When you need us, we are there.



DURA•TECH

Contact us!

www.sparksbelting.com
customerservice@sparksbelting.com
(800) 451-4537 | Fax (800) 338-2358



Headquarters & National Manufacturing Center:
5005 Kraft Ave Grand Rapids, MI 49512