

# 3.19 DURA•DRIVE SPM

Synchronous Permanent Magnet Motorized Pulley

The Dura-Drive Synchronous motorized pulleys are high powered, high efficiency motors that help lower energy costs by running more efficiently and in turn, meeting current energy efficiency regulations. The permanent magnet design is the key to the high efficiency and the power density. Best for applications in logistics, general automation, machine building, and are especially suited for servo-type applications.



### Oil Free

Dura-Drive SPM pulleys run oil-free meaning no possibility of oil leaks. This solves one of the main problems of motorized pulleys, especially in food applications. Oil-free provides high power with no need for oil cooling eliminating any chance of leakage. Additionally, there is practically no conveyor downtime or maintenance and that leads to lower costs and higher productivity.

### Simple Design

Dura-Drive SPM is a one-piece pulley so it can be easily specified into new conveyor systems, which dramatically reduces design time. For existing systems the pulleys can be ordered with two mounting brackets for an easy retrofit. Because it's compact, and all moving parts are enclosed in the pulley shell, there is less concern of hazards and pinch points and there's no external grease or oil from chains, bearings and couplings.

### Cool Running

The permanent magnet motor allows for the pulley to run at high power and very low electrical and mechanical losses. This results in significantly reduced heat when compared to a motorized pulley powered by a standard AC induction motor.

### Standardization

Due to the constant torque over a broad speed range, one Dura-Drive SPM can cover a wide range of applications.

### Constructions & Materials

Component	Standard	Options
Shaft	Mild Steel	Stainless Steel
Shell	Mild Steel	Stainless Steel
	Crowned	Rubber Lagged
		Flat Face
		V-Grooves
		Sprockets
		Hard Chrome
End Caps	Mild Steel	Stainless Steel
Sealing	IP66	IP69K
Electrical Connections	Straight brass connector with 1.5 meter cable (longer cable lengths available)	Stainless Steel elbow connector with 1.5 meter cable (longer cable lengths available)
		Stainless Steel terminal box
Motor Insulation	Class F	

### Electrical Connections

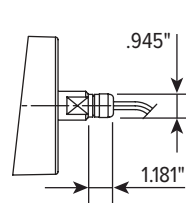

Straight brass connector with 1.5m cable (longer cable lengths available)

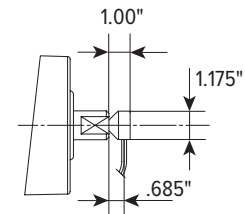

Stainless Steel elbow connector with 1.5m cable (longer cable lengths available)

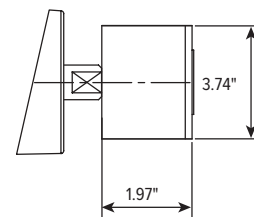

Stainless Steel terminal box



### Motorized and Idler Pulley Dimensions

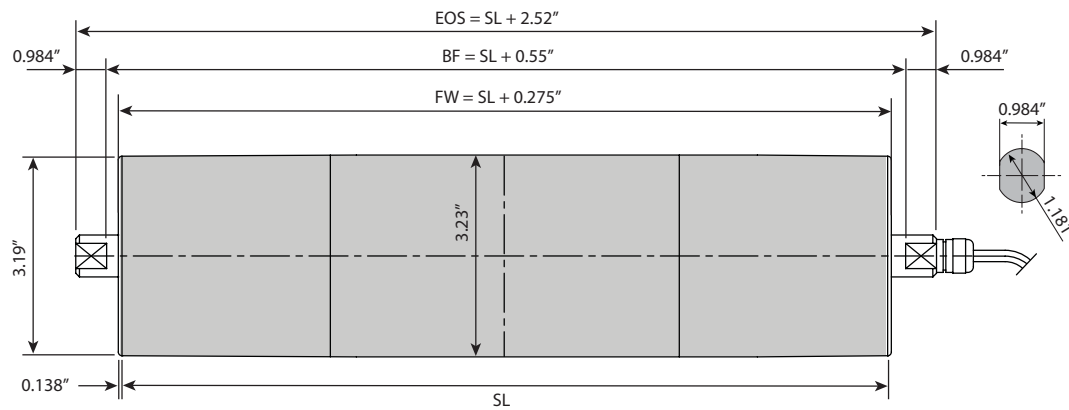

### Mounting Bracket

Material: Cast iron or stainless steel bracket

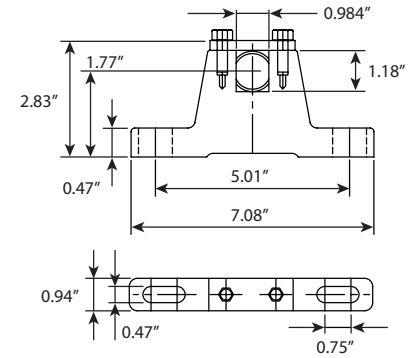

### Standard Gearbox

HP	Minimum Shell Length	RPM	FPM (nominal)	Belt Pull (lbs)	Drum Torque (lbs-ft)
0.50	11.81"	94	79	199	26.6
		150	126	124	16.6
		<b>188</b>	<b>158</b>	<b>99</b>	<b>13.3</b>
		250	211	74	10.0
		375	316	51	6.8

\*\*Bold blue numbers designates special order items.

- Speed adjustments in the following ranges are possible:
  - Sensor-less operation with a suitable frequency inverter: 10:1 is normal, 15:1 possible
  - Servo drive and feedback: up to 1,000:1
- Starting torque:
  - Sensor-less: rated torque x 1.5
  - With feedback: peak torque
- Shell lengths (SL) up to 40", contact Sparks Customer Service for longer lengths
- Other shaft size options are available
- Contact Sparks customer service for lagging and v-groove options

### Motor Data (Required for VFD Programming)

Motor		0.50HP
Power	HP (kW)	0.50 (0.37)
Nameplate / Maximum Frequency	Hz	150
Nominal rotational speed	$n_n$	3,000
Pole pairs		3
Electrical connection		Y
Stator Rated Voltage	V	181
Rated torque [ Nm ]	$M_n$	1.2
Nominal current per phase [ $A_{rms}$ ]	$I_n$	1.5
Stall torque [ Nm ]	$M_o$	1.5
Locked rotor current per phase [ $A_{rms}$ ]	$I_o$	1.8
Peak torque [ Nm ]	$M_{max}$	6.0
Peak current [ $A_{rms}$ ]	$I_{max}$	7.2
Voltage constant (per 1.000 RPM) [ $V_{rms}$ ]	$k_e$	51.7
Back EMF	$V_{rms}$	155.1
Torque constant [ Nm/ $A_{rms}$ ]	$k_t$	0.86
Winding resistance (phase to phase at 68°F) [ $\Omega$ ]	$R_{pp}$	9.8
Winding inductance (phase to phase) [ mH ]	$L_{pp}$	18.6
Electrical time constant [ ms ]	$T_{el}$	1.9
Rotor inertia [ $kgcm^2$ ]	J	0.413

### Dura-Drive SPM Servo

Dura-Drive SPM motors can be fitted with a standard feedback device (resolver or Hyperface Sin / Cos encoder) and in combination with most standard servo drives used as a PM servo. Run in this mode, the motor can achieve up to 500% of rated torque and be controlled in a speed range of about 1000:1.

Servo Drives	
Manufacturer	Type
Lenze	Servodrive 9400 HighLine (Resolver)
Schneider Electric	PAC Drive 3 (SKS36)
KEB	Combivert F5 (Resolver)
	Combivert S6 (Resolver & Sensorless)

Frequency Inverter/Sensorless	
Manufacturer	Type
Allen Bradley	<b>PowerFlex 525</b>
	PowerFlex 753
Invertek	Optidrive P2
	Optidrive E3
Lenze	i550
	Highline 8400
	Stateline 8400
Hitachi	WJ200
Nord	SK 215E
SEW	Movitrac LTP-B
Schneider Electric	Altivar 32

\*\*The inverters in bold blue print above are stocked by Sparks and come pre-programmed.

### Connector Pin Assignment

#### Power

Color/Code	Function
black/1	U
black/2	V
black/3	W
green-yellow	ground
brown	thermal
white	thermal

#### Resolver

Color/Code	Function
white	REF +
brown	REF -
green	SIN +
yellow	SIN -
pink	COS +
grey	COS -

### SKS36 Encoder

Color/Code	Function
grey	DATA +
green	DATA -
white	SIN +
brown	REF SIN
pink	COS +
black	REF COS
red	US (8 V DC)
blue	GND (0 V DC)

### Thermal Protection

The Dura-Drive SPM motorized pulley is fitted with either a KTY84-130 switch or PTC temperature sensor. The temperature sensor must be monitored by an external circuit, such as a frequency inverter, which switches off the power to the motor if the maximum temperature is exceeded.

### Option: Motor feedback

Dura-Drive SPM motorized pulleys can be supplied with resolver or SKS36 feedback.

### Resolver

Number of poles	2
Input frequency	10kHz
Input voltage	Vrms
Connection	Signal cable 6 x 0.14 qmm (AWG 26) shielded

\*The optional components increase the minimum face width of the pulley by +1.34".

### SKS36 Encoder

Number of Sin/Cos periods per revolution	128
Number of absolute revolutions	1 (single turn)
Resolution	4096
Connection	Signal cable 8 x 0.15 qmm (AWG 26) shielded
Supply voltage	7 to 12V DC

\*The optional components increase the minimum face width of the pulley by +2.09".



## Contact us!

[www.sparksbelting.com](http://www.sparksbelting.com)  
[customerservice@sparksbelting.com](mailto:customerservice@sparksbelting.com)  
(800) 451-4537 | Fax (800) 338-2358



---

Headquarters & National Manufacturing Center:  
**5005 Kraft Ave Grand Rapids, MI 49512**